

Slip Form Belt Conveyors



The Slip Form belt conveyor is an essential part of many conveying and storage systems dealing with grains, seeds and many other granular or pelletised products. They are easily maintained due to their simple construction and low power requirement, this makes them ideal as a cost-effective in-plant conveying solution, with many applications in manufacturing and processing industries.

This well-established design comprises a one piece casing, precision formed from galvanised sheet, with integral belt return rollers. The conveyor belt is a multi-ply, synthetic fibre construction with a PVG top cover running in the formed steel trough. Product can be discharged at fixed or variable intermediate positions along the conveyor length using the wide range of tripper carriage options available.

Designed for low to medium capacity conveying of a wide range of materials, the Guttridge Slip Form belt conveyor range is ideally suited to medium duty commercial and industrial applications.

- Simple one piece folded construction
- Galvanised construction, optional stainless steel
- Available in 3 model sizes with capacities up to 120m³/hr
- Versatile tripper carriage system for intermediate discharge
- Optional enclosure panels for dust containment
- Wide range of options to allow easy customisation

Slip form belt conveyors are in operation in many different industry sectors handling a wide variety of different materials:-

Foods - rice, miscellaneous seeds, grains and granules

Animal Feeds, Pet foods and Cereals - wheat, barley, corn, peas, beans, seeds, extruded products, grains, pellets and granules

Chemicals, Biomass and Minerals - wood chips and pellets, sawdust, shredded plastics and rubber, general non-abrasive granular materials



Guttridge

Drive

The standard drive arrangement comprises a shaft mounted speed reducer on the conveyor shaft, driven from a standard 4 pole electric motor to IP55 specification. A Vee-belt drive is enclosed within a sturdy drive guard assembly. Optional variations to the standard drive, typically gear motor units, mechanical or electrical variable speed units etc. can be provided for special requirements.

Optional rotation sensor, available fitted to the tail end to sense underspeed.

Note: Photograph opposite shows optional white food quality belt.



Tripper Carriage

A mobile discharger unit mounted on four steel wheels giving clean efficient uploading of the belt at any position along the conveyor's working length. Available for manual or motorised operation and supplied with a tripper valve which enables discharge to either side of the conveyor. The manual tripper is traversed along the conveyor by hand, it is fitted with a brake mechanism for locking in the desired position. Motorised trippers are mechanically moved via traction cables, by a stationary 0.18kW geared motor normally fitted at the drive end. These trippers are supplied with 2 micro switch units to limit the tripper travel, extra switches can be used to give intermediate stops along the conveyor's working length. The motorised tripper can discharge material whilst stationary or when on the move making it ideal for above floor stores and open topped bin systems.



Spreader Tray

A tripper attachment that replaces the standard two way valve. Designed to give equal discharge to each side of the conveyor making the spreader ideal for use above floor stores.

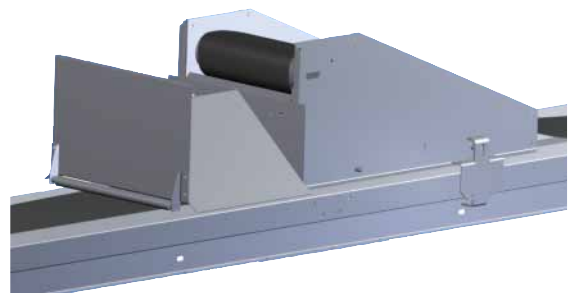

Construction

The Slip Form conveyor casing is a one piece rigid section, precision formed with the latest computerised metal folding equipment, giving accurate form with the precise butt joints. The slip form design forms the belt into a trough and supports it fully over the length of the conveyor. Steel rollers with integral sealed bearings support the return belt on the underside of the case, these belt return rollers are adjustable to assist belt tracking.

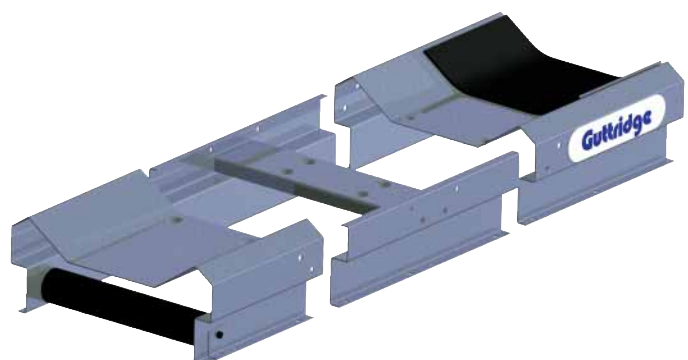

Belt and Tensioning

The standard conveyor belt is a multi-ply, synthetic fibre carcass with a PVG top cover and a GEM type laced joint, optional on-site vulcanised joint (by others). Belt tension is applied at the tail end by two positive screw adjusters. The tail end hinges upwards to slacken the belt fully for easy maintenance and cleaning. A full range of alternative belting is available including heat resistant and food quality types.



Universal Loading Hopper

A loading attachment giving high deposit rate with a degree of capacity control. Steel rollers with sealed bearings form the belt into a deep "U" trough to eliminate spillage and minimise drag. The hopper can be positioned at any point along the conveyor working length and can be loaded in either direction. Multiple loading points are also possible using a number of hoppers as material already on the belt can pass through without spillage. An optional hopper chute is available to increase the feed area.



End Outlets

An optional hopper to collect material discharged at the drive end pulley. Brushes are fitted within the hopper to assist clean discharge.

An optional tail end hopper is available for use on reversing machines to collect material discharged at the tail end.



MODELS AVAILABLE

Model	Case Size	Capacity
300	425 x 180mm	30 - 40 tonnes/hr
380	500 x 180mm	45 - 55 tonnes/hr
500	650 x 250mm	75 - 90 tonnes/hr

Notes

1. Capacity is based on dry wheat at 750kg/m³
2. The nominal capacity is based on a standard belt speed of 1.5m/sec. Alternative drive arrangements giving a belt speed up to 2.25m/sec can be considered for certain materials which will increase the capacity proportionately.

Specifications and dimensions may be altered without prior notice.



Miscellaneous Options

Belt Take-Up Unit

For long machines additional belt adjustment can be achieved with this compact unit which fits on the underside of the case close to the tail end. The unit has four rollers, three fixed and one with positive screw adjusters capable of displacing over half a metre of belt, thus reducing the number of times the belt requires shortening and re-joining.



Reload Attachment

The reload attachment is supplied with a universal loading hopper, together they are used to reload the belt with material off the tripper carriage. This fitting replaces the two way side discharge valve.

Rotary Brush

A power driven rotary brush fitted within the drive end outlet to clear the belt of fines at the discharge point.

Apex Covers

Available to enclose the belt for weather protection, safety or to aid dust suppression.

Specialist Manufacturers of Materials Handling Machinery

We serve a wide range of industry sectors with our comprehensive range of materials handling machinery. A full description of our complete range of products is beyond the scope of this brochure, but we list brief details below -

Feeds, Cereals, Chemicals, Minerals

Screw Conveyors & Bin Dischargers
Chain & Flight Conveyors
Hiload Bucket Elevators, Belt Conveyors
Spouting, Fittings & Slide Valves
Fountain Blenders/Live Bins
En-Masse Conveyors
Bulk Bag Fillers & Dischargers
Special Fabrications

Foods, Chemicals, Pharmaceuticals

Easyflo Mobile Screw Elevator
Sieveflo Screw Elevator/Check Sieve
Multiflo & *Augaflo* Screw Conveyors
Bulkflo Mobile Loading Hopper with
integral Screw Elevator
*A range of machines designed to be easily
dismantled for cleaning*
Bulk Bag Fillers & Dischargers

Our machinery is in regular use all over the world and we have Agency and Distribution Agreements with companies in many different countries. Please contact us for further details.

Guttridge SERVICES LTD

Wardentree Park, Pinchbeck,
Spalding, Lincolnshire,
PE11 3UU, ENGLAND
Tel: 44 (0) 1775 765300
Fax: 44 (0) 1775 765301
Email: sales@guttridge.co.uk
Web: www.guttridge.co.uk